

Manual

WEGA & ALTR LED Luminaires system

Inhoud

Agrolux | WEGA ECO, -PLUS, -MAX and ALTR

1. Introduction	3
2. Product description	3
2.1. WEGA ECO, -PLUS, -MAX	3
2.2. ALTR	3
3. Used symbols	3
4. Product information	4
4.1. Compatible products and accessories WEGA ECO, -PLUS, -MAX and ALTR	4
4.2. Environment	4
4.3. Legal	4
5. Safety recommendations and warnings	5
6. Contents	6
7. Installation	7
7.1. Installation preparations	7
7.2. Installing the luminaire	7
7.3. Installing the fall protection	7
7.4. Safe power cord connection	7
7.5. Connecting the luminaire to the mains	8
7.6. Connecting with PLC transmitter (sold separately)	8
7.7. Disconnecting the Wieland RST20i3 plug	8
8. Precautions when using the luminaire	8
9. Inspection, maintenance and repair	9

Agrolux | General

1. Cleaning	20
1.1. Before cleaning	20
1.2. Regular inspection	20
1.3. Cleaning	20
2. Warranty	21
3. Storage and disposal	21

Agrolux | PLC Transmitter Gen 2

1. Introduction	10
2. Product description	10
3. Product information and specifications	10
3.1. General product information	10
3.2. Technical specifications	10
3.3. Compatible product and accessories	11
3.4. Environment	11
3.5. Legal	11
4. Safety recommendations and warnings	11
5. Contents	12
6. Controls, connections and indications	12
6.1. Status indicator light definition	12
6.2. Restart button	12
7. Installation	13
7.1. Installing the transmitter	13
7.2. Connecting the transmitter to the mains	13
8. Connecting the dimming interface	14
8.1. Setting up the dimming interface for control with Modbus-TCP	14
8.2. Setting up the dimming interface for control with Modbus-RTU (RS485)	14
8.3. Setting up the dimming interface for control with 0 - 10 VDC	14
9. Commissioning	15
9.1. Introduction	15
9.2. Duration per transmitter	15
9.3. Important commissioning preconditions	15
9.4. Commissioning	15
9.5. Information handling	17
9.6. Transmitter control	17
9.7. Temporary manual dimming set-up	18
9.8. Commissioning with groups	19

1. Introduction

This manual describes the mounting and installing of the product and also describes how to use the product. Mounting and installing of the luminaire may only be executed by certified service personnel. Please read and understand this manual completely before using the luminaire. Only use the luminaire as specified in this manual.

2. Product description

2.1. WEGA ECO, -PLUS, -MAX

The Agrolux WEGA Eco, -Plus, and -Max are solid state horticultural LED luminaires. They are equipped with two high intensity LED panels.

Part of the WEGA Plus, and -Max models include a Power Line Communication (PLC) module. The PLC module performs digital communication with a PLC transmitter (sold separately) over the AC power line to achieve dimming control. See the general product information (chapter 4.1 and 4.2) for an overview of which models are suitable for use with PLC. In this manual, the Agrolux WEGA Eco, -Plus, and -Max will be referred to as: “the luminaire”.

2.2. ALTR

The Agrolux ALTR are solid state horticultural LED luminaires. They are equipped with two high intensity LED panels. In this manual, the Agrolux ALTR will be referred to as: “the luminaire”.

3. Used symbols

 **Warning!** A warning indicates severe damage to the user and/or product may occur when a procedure is not carried out as described.

 **Caution!** A caution sign indicates problems may occur if a procedure is not carried out as described. It may also serve as a reminder to the user.

 **Note:** A note gives additional information, e.g. for a procedure.

 This symbol indicates that the luminaire can reach high temperatures (>85 °C / 185 F). Observe a cool down period before performing maintenance.

 This symbol is an internationally recognized symbol used to designate recyclable materials.

 With this symbol Agrolux declares that this product complies with European requirements.

 This device complies with Part 15 of the FCC Rules. Operation is subject to the following two conditions: (1) this device may not cause harmful interference, and (2) this device must accept any interference received, including interference that may cause undesired operation.

 This symbol shows that a product has been independently tested and certified to meet recognized standards for safety.

 The symbol on the material, accessories or packaging indicates that this product may not be discarded as household waste. By disposing of the equipment in the proper way, you will be helping to prevent possible risks to the environment and public health, which might otherwise be caused by improper handling of the discarded equipment. Recycling of materials contributes to the conservation of natural resources. Therefore, please do not dispose of your old electronics and electrical appliances via household waste.

 This symbol indicates the minimum distance (B) between the luminaire (A) and the lit surface.

 This symbol indicates a risk of electric shock. Do not remove the lens. There are no serviceable parts inside the luminaire.

4. Product information

4.1. Compatible products and accessories WEGA ECO, -PLUS, -MAX and ALTR

	Product name	Part number	Certification
Compatible power cords	Agrolux RST Mains cable DCA 0.9m	CB9326434	CE
	CB9326435 - RST2013 MAINS CABLE UL/CSA 0.9M GRN FEM	CB9326435	UL/CSA

4.2. Environment

The product is intended to be used in greenhouses and climate rooms. The product can be used in humid environments. The product may not be used in wet environments or outdoors. The lamps function optimal when the ambient temperature is between 20 ~ 30 °C (68 ~ 86 F). For optimum operation a minimum clearance of at least 35 cm / 14 inch must be maintained in all directions.

⚠ Warning! This luminaire is suitable for operation in an ambient temperature not exceeding 35°C (WEGA ECO, -PLUS, -MAX) or 45°C (ALTR). This should be the maximum sustained temperature of the installed environment (ambient temperature) that will ensure safe operation of the lighting equipment. To prevent sustained temperatures above the maximum ambient temperature, a mechanical ventilation or cooling system is required to maintain the temperature within the growing space when the luminaire is in operation.

4.3. Legal

4.3.1. WEGA ECO, -PLUS, -MAX

Approval according to:

IEC 60598-1:2020, EN 60598-2-1:2020, EN IEC 60598-2-1:2021, EN IEC 60598-1:2021 + AMD11:2022
EN IEC 55015:2019+A11:2020, EN IEC 61000-3-2:2019, EN 61000-3-3:2013+A1:2019, EN 61547:2009
EN 50561-1:2013, EN 50412-2-1:2005

CSA C22.2#250.0:2021 Ed.5, UL 1598:2021 Ed.5 ANSI/CAN/UL 8800:2022
FCC Part 15, Subpart B, CAN ICES-005 (B) / NMB-005 (B)

4.3.2. ALTR

Approval according to:

EN IEC 60598-1:2021/A11:2022; EN IEC 60598-2-1:2021 ; EN IEC 55015 :2019; EN 61547 :2009;
EN IEC 61000-3-2:2019 ; EN 61000-3-3:2013+A1:2019 ; EN 50561-1:2013 ; EN 50412-2-1:2005

CSA C22.2 No. 250.0:21 Ed.5th; UL 1598:2021 Ed.5th; UL 8800:2023A Ed.1st; FCC Part 15B:2021;
ICES-005 issue 5; ICES-006 Issue 3.

5. Safety recommendations and warnings

⚠ Warning! Carefully read the warnings below before using or working with the product!

- Always adhere to the local rules and regulations when installing or using the luminaire.
- Do not open or disassemble the luminaire, it contains no servicable parts inside. Opening the luminaire can be dangerous and will void the warranty.
- The light source contained in this luminaire shall only be replaced by the manufacturer or his service agent or a similar qualified person.
- This product may cause interference to radio equipment and should not be installed near maritime safety communications equipment or other critical navigation or communication equipment operating between 0.45 - 30 MHz.
- Do not use the luminaire when either its optics, heatsink or power cord are damaged. Replace the power cord only with original certified cords.
- Modifications to the cords can lead to unwanted electromagnetic effects, which makes the product not comply with legal requirements.
- Do not expose the luminaire to:
 - condensing humidity, heavy mist, fog or direct spray;
 - (ambient) temperatures outside the specified range;
 - dust and contamination;
 - direct sunlight during use or HID light that could heat up the luminaire.
- Always disconnect the luminaire from mains before performing any maintenance.
- Always allow for a cool down period of at least 30 minutes before touching the LED-panel and the luminaire. Touching the LED-panel or the luminaire when the lamp is lit or immediately afterwards will result in severe burns!
- Do not use the luminaire near or above flammable, explosive or reactive substances. The LED-panel and the luminaire reach temperatures up to 85 °Celsius.
- Do not use sulfur vaporizers or water misters. Sulfur and calcium deposits on the optics will decrease its efficiency.
- The installation and use of the luminaire is the responsibility of the end user. Incorrect use or installation can lead to failure and damage to the luminaire. Damage to the luminaire and electronic circuitry as a result of incorrect installation and use revokes the warranty.
- Please note that changes or modifications of this product is not expressly approved by the party responsible for compliance could void the user's authority to operate the equipment.
- The installation and use of the luminaire is the responsibility of the end user. Incorrect use or installation can lead to failure and damage to the luminaire. Damage to the luminaire and electronic circuitry as a result of incorrect installation and use revokes the warranty.

- **Note:** This equipment has been tested and found to comply with the limits for a Class B digital device, pursuant to Part 15 of the FCC Rules. These limits are designed to provide reasonable protection against harmful interference in a residential installation. This equipment generates, uses and can radiate radio frequency energy and, if not installed and used in accordance with the instructions, may cause harmful interference to radio communications. However, there is no guarantee that interference will not occur in a particular installation.

If this equipment does cause harmful interference to radio or television reception, which can be determined by turning the equipment off and on, the user is encouraged to try to correct the interference by one or more of the following measures:

- Reorient or relocate the receiving antenna.
- Increase the separation between the equipment and receiver.
- Connect the equipment into an outlet on a circuit different from that to which the receiver is connected.
- Consult the dealer or an experienced radio/TV technician for help.

6. Contents

- A. Agrolux WEGA Eco (1), -Plus (2), -Max (3) or Agrolux ALTR (4)
- B. Mounting points
- C. Wieland RST20i3 male connector

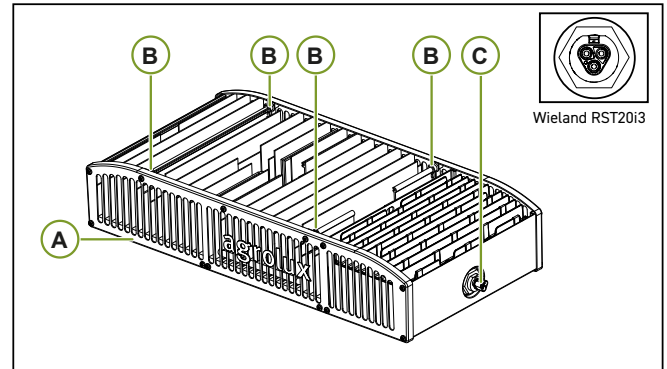
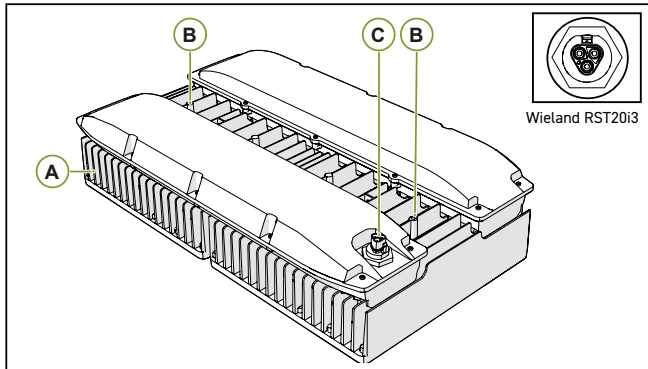
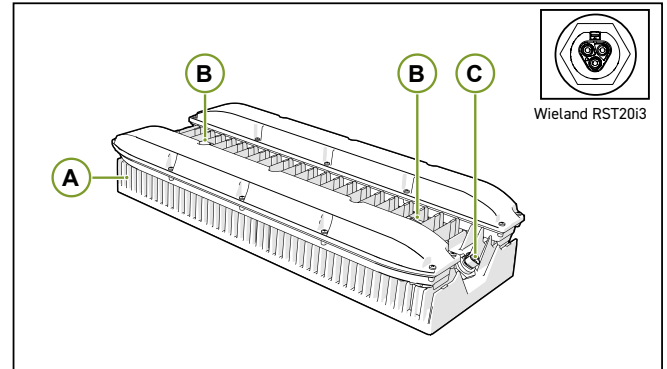
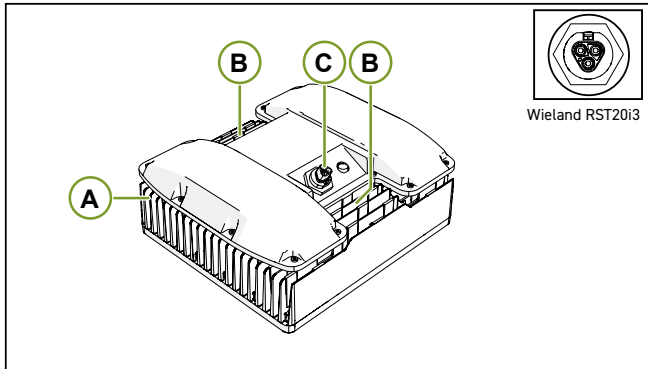

7. Installation

- ⚠ **Warning!** Mounting and installing of the luminaire may only be executed by certified service personnel, in accordance with the applicable local laws and regulations.
- ⚠ **Warning!** The fitter is responsible for correct and safe installation.
- ⚠ **Warning!** Ensure the local cabling can support the voltage and current requirements of the luminaire.
- ⚠ **Warning!** Avoid coiled cords and keep mains leads separated. This prevents electromagnetic interference.
- ⚠ **Warning!** Do not connect or disconnect the Wieland RST20i3 plug under load.
- ⚠ **Warning!** The luminaire should be positioned so that prolonged staring into the luminaire at a distance closer than 3.33 m is not expected.

7.1. Installation preparations

- Switch off mains power.
- Read the Agrolux light distribution plan.

7.2. Installing the luminaire

- Mount the suspension bracket¹ according to the light distribution plan.
- Hang the luminaire by its two mounting points onto the suspension bracket (5). Keep a minimum free space of 35 cm / 14 in around the luminaire for efficient cooling.
- ⚠ **Caution!** Ensure the luminaire hangs horizontally for the best performance.
- If the luminaire cannot be mounted with the integrated mounting points, screw two eye bolts into the luminaire (6) (spacing Eco, Plus: 417.8 mm (16.45 in) / spacing Max: 284.5 mm (11.20 in). The eye bolts must be used as a mounting point of a drop protection.

To install more luminaires, repeat the steps above.

¹ The suspension bracket is delivery dependent, it may differ from the image.

7.3. Installing the fall protection

- Attach the carabiner to the eye bolt.
- Hang one side of the steel cable on the carabiner.
- Wind the steel cable around the truss.
- Hang the other side of the steel cable on the carabiner. Make sure the steel cable hangs tight (7).

7.4. Safe power cord connection

For lighting equipment with cords or wiring harnesses, that cords:

1. are not concealed or extended through a wall, floor, ceiling, or other parts of the building structure;
2. are not located above a suspended ceiling or dropped ceiling;
3. are not permanently affixed to the building structure;
4. are routed so that they are not subject to strain and are protected from physical damage;
5. are visible over their entire length; and
6. are used within their rated ampacity as determined for the maximum temperature of the installed environment specified in the instructions.

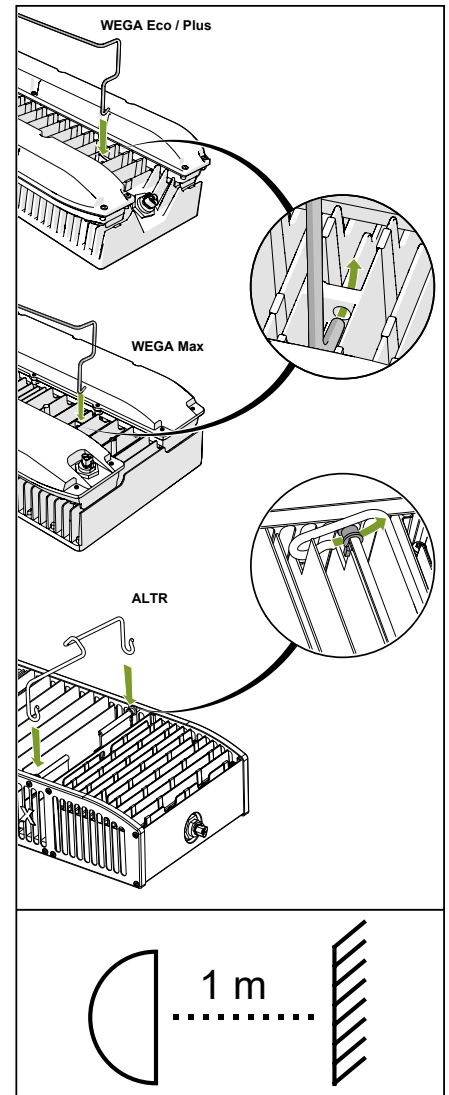

5.

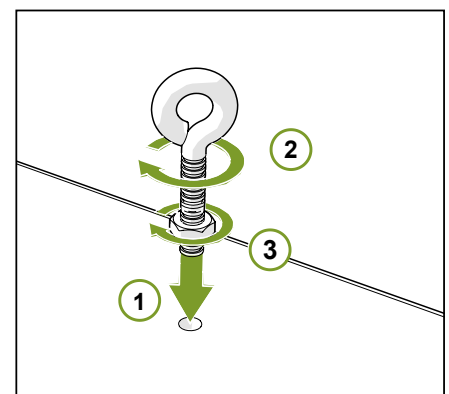

6.

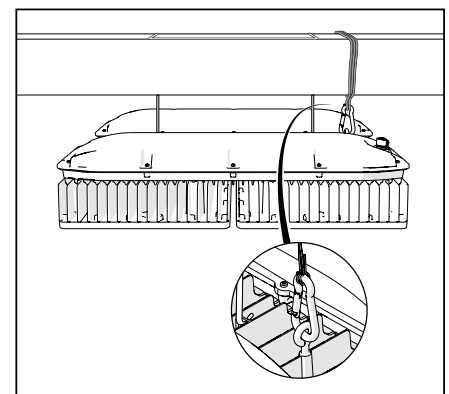

7.

7.5. Connecting the luminaire to the mains

- ⚠ For North America: **CAUTION - PROPRIETARY WIRING SYSTEM.** Use Agrolux RST Mains cable CB9326435 only for connection from the luminaire power inlet to a standard junction box for power connection. Note that model CB9326435 is provided with the luminaire.
 - ⚠ **Warning!** Make sure mains power is switched off.
 - ⚠ **Warning!** Ensure the cord is not coiled and does not touch any hot surfaces.
 - ⚠ **Warning!** Connect the cables according to local rules, safety regulations and electrical code.
 - ⚠ **Warning!** Ensure external switching gear can cope with the inrush current of the luminaire. Always use a double pole contactor suitable for switching a capacitive load. Never use household timers to switch the luminaire!
1. Connect the wires of the female Wieland RST20i3 cable with the distribution cable of the electrical installation.
- ⚠ **Caution!** Use a suitable sealed joint to connect the cables.

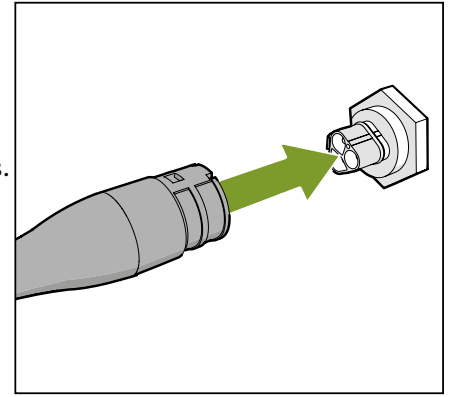

8.

Cable description 400 V systems:

Wire	240V	400V
Brown	Phase (L)	Phase (L)
Blue	Neutral (N)	Phase (L)
Green/yellow	Ground (⊕)	Ground (⊕)

- ⚠ **Warning!** Make sure the wires are connected correctly to prevent short-circuit.
2. Plug the Wieland RST20i3 female connection onto the Wieland RST20i3 male connection of the luminaire (8).
- ⚠ **Caution!** After connecting the Wieland connectors, ensure the luminaire still hangs horizontally for the best performance. Ensure the cable is not under any tension when leveling the luminaire horizontally.
3. Switch on mains power.
- ⚠ **Warning!** Do not connect or disconnect the Wieland RST20i3 plug under load.

7.6. Connecting with PLC transmitter (sold separately)

The luminaires that include PLC modules are installed the same as normal luminaires. After installing the luminaires, please refer to the PLC transmitter instructions in this manual for detailed commissioning and dimming control instructions.

7.7. Disconnecting the Wieland RST20i3 plug

- ⚠ **Warning!** Do not connect or disconnect the Wieland RST20i3 plug under load.
1. Switch off mains power.
 2. Press the pin on the Wieland RST20i3 male connection downwards and pull the Wieland RST20i3 female connection from the luminaire (9).

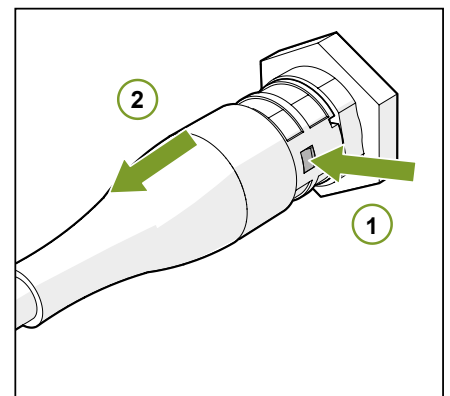

9.

8. Precautions when using the luminaire

- ⚠ **Warning!** Never touch the fixture for at least one minute after switching off the power to allow residual voltage to discharge to a safe level.
- ⚠ **Caution!** A maximum of two switch cycles (on/off) per day is allowed.

9. Inspection, maintenance and repair

Note: See “Cleaning” in the back of this manual for more information and instructions on the cleaning and maintenance of the luminaires.

Warning! Disconnect the product from mains before performing any maintenance.

Warning! Do not connect or disconnect the Wieland RST20i3 plug under load.

Warning! Do not open or disassemble the luminaire, it contains no servicable parts inside. Opening the luminaire can be dangerous and will void the warranty.

Warning! Always allow for a cool down period of at least 30 minutes before touching the lamp or luminaire.

Caution! Do not clean the luminaire with detergents, abrasives or other aggressive substances.

Caution! Do not touch the optics with your hands.

- Do not use a high pressure water gun.
- Do not touch the optics with your hands and only use the correct cleaning products.
- Regularly check the luminaire for dust or dirt buildup. Clean if necessary.
Contamination may cause overheating and decreased performance.
 - Clean the outside of the luminaire using a dry or damp cloth.
- Regularly check the wiring of the product to ensure it is undamaged.

Caution! The highly transparant optics are sensitive to contamination. Cleaning needs to be done with care.

1. Introduction

This manual describes the mounting and installing of the product and also describes how to use the product. Mounting and installation of the Agrolux PLC Transmitter may only be executed by certified service personnel. Please read and understand this manual completely before using the product. Only use the product as specified in this manual.

2. Product description

The Agrolux PLC Transmitter is a controller for horticultural LED luminaires. The system consists of this transmitter and receiver inside the luminaires. The signal is sent over the power cables.

The Agrolux PLC Transmitter is intended to be used in greenhouses, climate controlled growing rooms, and similar controlled environment indoor agriculture spaces. In this manual, the Agrolux PLC Transmitter will be referred to as: “the transmitter”.

3. Product information and specifications

3.1. General product information

Product name	Agrolux PLC Transmitter Gen 2
Manufacturer	Gavita International B.V.
EAN Code	8718692230217
P/N	HW8991004

3.2. Technical specifications

Product name	Agrolux PLC Transmitter Gen 2
Product weight	260 g
Dimensions (L × W × H)	108 × 112 × 56 mm
Temperature ambient	-20 - 60 °C
Relative humidity	5 - 90% (non-condensing)
Input voltage	3 Phase 4 Wire (With Neutral): 230/400 VAC, 277/480 VAC, 347/600 VAC 3 Phase 3 Wire (Without Neutral): 400 VAC
Frequency	50 - 60 Hz
Power consumption	2 W
Frequency band	2.5 - 5.7 MHz
Connections	Modbus RTU (Horti Lighting Protocol) Modbus TCP (Horti Lighting Protocol) 0 - 10 V (2×)
IP rating	IP20

Product name	Agrolux PLC Transmitter Gen 2
Mounting	7.5 mm DIN rail (Top hat rail IEC/EN 60715) TS35 in USA
Maximum cable length between transmitter and luminaire *	150 m
Maximum amount of luminaires per transmitter *	60
Maximum amount of transmitters per transformer *	24

* For different configurations, please contact Agrolux.

3.3. Compatible product and accessories

WEGA dimmable luminaires.

3.4. Environment

The product is intended to be used in greenhouses and climate rooms. The product may not be used in wet environments or outdoors.

3.5. Legal

CE/CB: IEC/EN 61347-2-11, IEC/EN 61347-1; ROHS: 2011/65/EU, EU 2015/863 CE EMC: EN 50561-1:2013, EN 50412-2-1:2005, EN 61000-3-2:2019, EN 61000-3-3:2013+A1:2019, FCC Part 15B, UL 8750:2015 Ed.2+R:07Dec2022, CSA C22.2#250.13:2022 Ed.5

4. Safety recommendations and warnings

⚠ Warning! Carefully read the warnings below before using or working with the product!

- Always adhere to the local rules and regulations when installing or using the transmitter.
- Do not open or disassemble the transmitter, it contains no serviceable parts inside. Opening the transmitter can be dangerous and will void the warranty.
- This product may cause interference to radio equipment and should not be installed near maritime safety communications equipment or other critical navigation or communication equipment operating between 0.45 - 30 MHz.
- Do not expose the transmitter to:
 - condensing humidity, heavy mist, fog or direct spray;
 - (ambient) temperatures outside the specified range;
 - dust and contamination;
 - direct sunlight during use or HID light that could heat up the transmitter.
- Always disconnect the transmitter from the mains before performing any maintenance.
- Do not use the transmitter near flammable, explosive or reactive substances.
- The installation and use of the transmitter is the responsibility of the end user. Incorrect use or installation can lead to failure and damage to the transmitter. Damage to the transmitter and electronic circuitry as a result of incorrect installation and use voids the warranty.

5. Contents

- A. Agrolux WEGA PLC Transmitter
- B. DIN rail lock

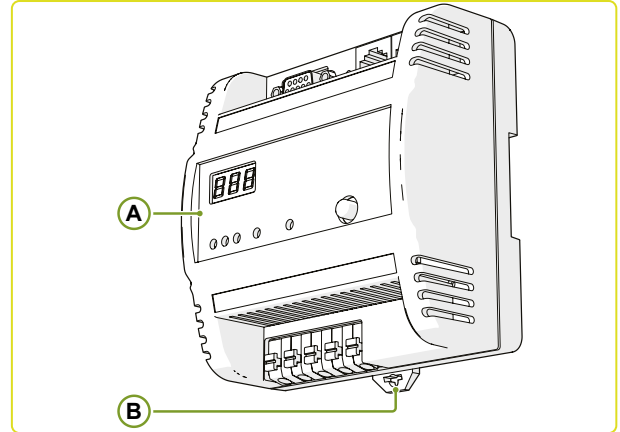

10.

6. Controls, connections and indications

- A. Display
- B. Running indicator light
- C. Status indicator light
- D. Key-press indicator light
- E. Network indicator light
- F. Mode indicator light
- G. RS-232 port
- H. Restart button
- I. RJ45 Ethernet port
- J. RJ45 RS-485 / 0 - 10 V input port
- K. Function button
- L. Push-pins

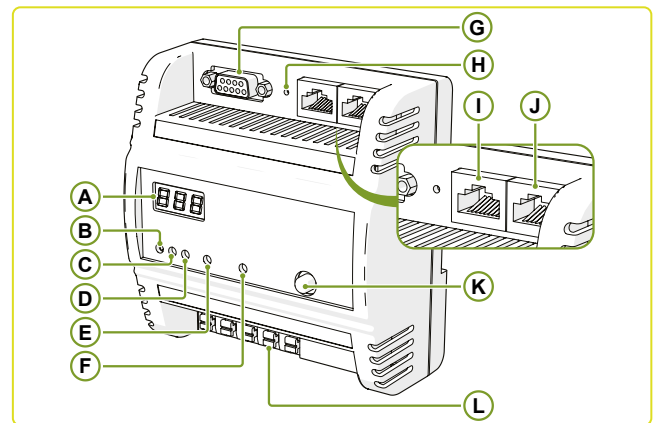

11.

6.1. Status indicator light definition

	Indicator light	Description
RUN	Running indicator light	Flashing when running normally
STA	Status indicator light	Flashing when running normally Quick flashing when setting up PLC network after power up and during commissioning
KEY	Key-press indicator light	Flashing when running normally Quick flashing when key pressed, release to switch mode
NET	Network indicator light	Flashing every time an ethernet data packet is received
MOD	Mode indicator light	OFF: normal operation (modbus / 0-10v) ON: Manual mode

6.2. Restart button

Use a thin tool (needle, SIM card tool) to press the button, this reboots the transmitter.

7. Installation

- ⚠ **Warning!** Mounting and installing of the transmitter may only be executed by certified service personnel, in accordance with the applicable local laws and regulations.
- ⚠ **Warning!** The installer is responsible for correct and safe installation.
- ⚠ **Warning!** Ensure the local cabling can support the voltage and current requirements of the transmitter.
- ⚠ **Warning!** Avoid coiled cords and keep mains leads separated. This prevents electromagnetic interference.

7.1. Installing the transmitter

To install the transmitter:

1. Pull out the DIN rail lock (12).
2. Hang the transmitter on a DIN rail inside a waterproof housing (13).
3. Press the DIN rail lock to lock the transmitter to the DIN rail (14).

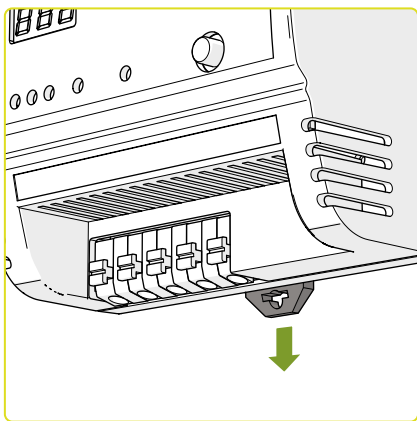

12.

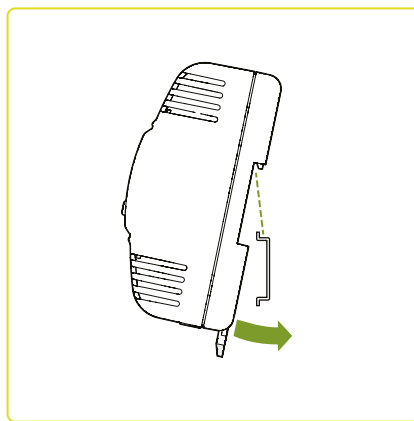

13.

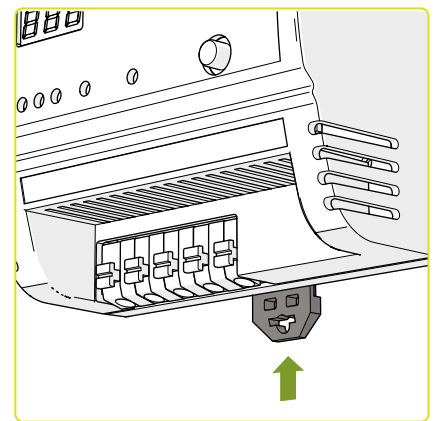

14.

- ⓘ **Note:** It is recommended to install a dedicated circuit breaker for each transmitter with a constant power supply. Do not connect the transmitter behind control relays to prevent power loss to the transmitter, rebuilding the communication network after a power loss takes up to 10 minutes.
- ⓘ **Note:** Prevent a loss of power to the transmitter. Rebuilding the communication network after a power loss takes time.

7.2. Connecting the transmitter to the mains

- ⚠ **Warning!** Make sure mains power is switched off.
 - ⚠ **Warning!** Ensure the cord is not coiled and does not touch any hot surfaces.
 - ⚠ **Warning!** Connect the cables according to local rules, safety regulations and electrical code.
1. Switch off mains power.
 2. Connect the transmitter to the mains using the push-pins. The transmitter can be connected to a 3 phase with neutral (15) or a 3 phase without neutral (16).
 3. Switch on mains power.
- ⚠ **Warning!** Do not connect or disconnect the transmitter under load.

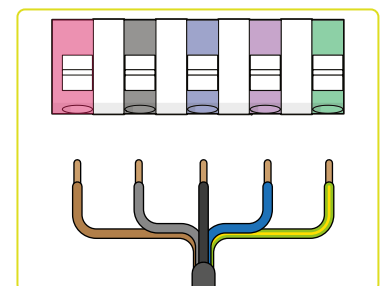

15.

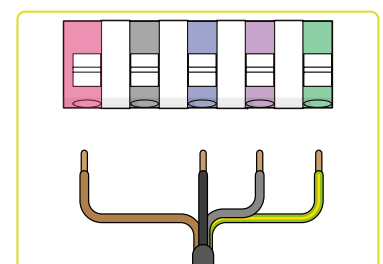

16.

8. Connecting the dimming interface

- I. RJ45 Ethernet port
- J. RJ45 RS-485 / 0 – 10 V input port

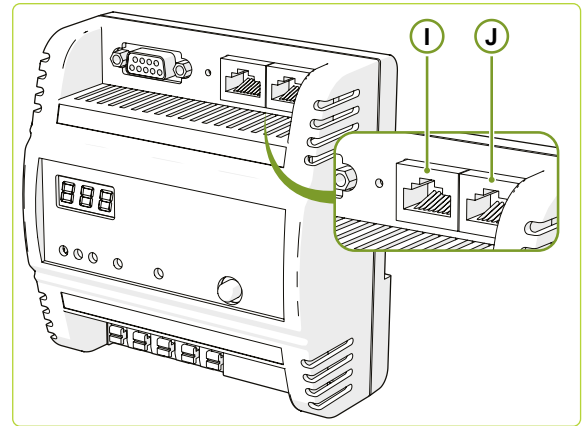

17.

8.1. Setting up the dimming interface for control with Modbus-TCP

1. Connect the Modbus-TCP cable in the RJ45 port “Ethernet” (A)

8.2. Setting up the dimming interface for control with Modbus-RTU (RS485)

1. Connect the Modbus-RTU (RS485) dimming controller to an RJ45 connector using the following pin layout.
2. Plug in the transmitter using the RJ45 port “0-10V Input” (B).

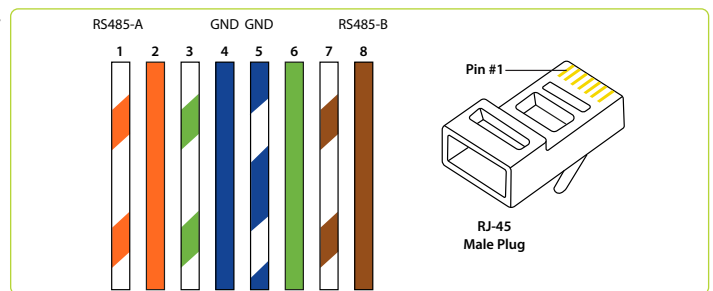

18.

Pin1	Pin2	Pin3	Pin4	Pin5	Pin6	Pin7	Pin8
Rs485-A			GND	GND			RS485-B

8.3. Setting up the dimming interface for control with 0 - 10 VDC

1. Connect a 0-10 VDC dimming controller to an RJ45 connector using the following pin layout. For single channel luminaires only connect DIM1 + and -. Dual channel luminaires require + and - for DIM1 and DIM2 to be connected.
2. Plug in the transmitter using the RJ45 port “0-10V Input” (B)

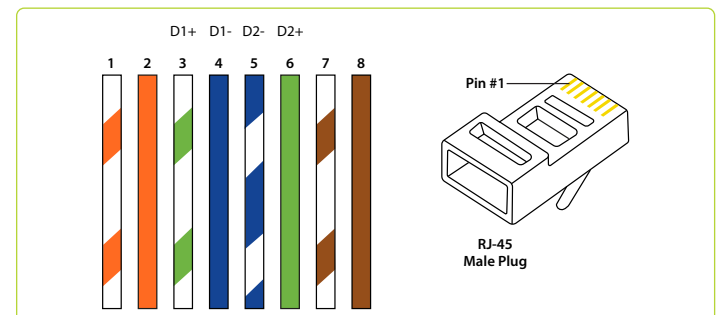

19.

Pin1	Pin2	Pin3	Pin4	Pin5	Pin6	Pin7	Pin8
		DIM 2+	DIM 2-	DIM 1-	DIM 1+		

9. Commissioning

9.1. Introduction

This chapter is written for a careful and successful step-by-step commissioning of the Modbus Horti Lighting Protocol Dimming Transmitters. It also highlights important points of attention. Additionally, during commissioning, it is important that if the switch cabinets are not accessible from the ground, an additional staff member should be present to move the monorail.

9.2. Duration per transmitter

Below is an estimate of the time required to commission a transmitter:

· If group of luminaires needs to be assigned	+/- 5 minutes
· If the maximum number of groups per transmitter (8 units*) need to be assigned	+/- 30 minutes

In addition to the above, additional transport time applies:

· Walking (panel/transmitter), easily accessible from the ground	3 minutes
· Monorail cart	15 minutes
· Electric monorail	5 minutes

- Note:** Maximum of 4 groups are recommended for best performance. The system will support up to 8 groups, however performance may be reduced. Please contact Gavita International customer service if over 4 groups are preferred.

9.3. Important commissioning preconditions

- Before commissioning, all luminaires must be connected and all transmitters must be turned off.
- Ensure the compartments being commissioned have a stable power supply.
- Ensure you can power the transmitter and the luminaires off and on during the commissioning.

For commissioning via option 2 (with a laptop) the following is needed:

- PC with the PC-CCO software and a Serial port (USB to serial will also work).
- A serial cable (RS-232).

9.4. Commissioning

There are two methods to commission:

- Manual (using the **button on the transmitter**)
- By software (using a **laptop**)

9.4.1. Commissioning using the button on the transmitter

Preparation:

Before proceeding, ensure that only the luminaires you intend to commission to this transmitter are powered on. Switch off all other luminaires and transmitters in the greenhouse, including those already commissioned. No other luminaires should be ON except the luminaires you are commissioning at the moment.

- Note:** Perform the network commissioning for every transmitter one by one.

PLC Network Commissioning Instructions



Step 1:

Power on the transmitter together with the luminaires and then wait for the transmitter's digital tube to display 888.

Step 2:

During the display of 888, press and hold the function button for 4 seconds and then release it (please note that the button needs to be released before the subsequent countdown ends) to enter the Power Line Carrier (PLC) networking state. (PLC networking operation is only required during the first installation of maintenance.)

Step 3:

The displayed number '1' should be consistent with the actual connected luminaires within 10 minutes. Press and hold the function button again for 4 seconds to end the PLC networking. Next, use RS485 Modus, 0-10 V to start dimming.

- ⓘ **Note:** If the transmitter gets stuck at a number of found luminaires, try power cycling the luminaires to speed up discovery.
- ⓘ **Note:** If the amount of luminaires on the display is not the intended amount of luminaires, check the wiring connections and restart the network commissioning process if necessary.
- ⓘ **Note:** The display reads the current dimming setting. Without a control signal, the transmitter and the connected luminaires are set to the default setting of 15% for single channel and 0% for dual channel. These settings can be modified using the CCO_FW Program.

9.4.2. Commissioning using PC_CCO software

Preparation:

1. Ensure you have a PC with the PC_CCO software, a serial port (RS-232) or a USB to RS-232 adapter and a serial cable.
2. Power off all luminaires and transmitters in the installation.

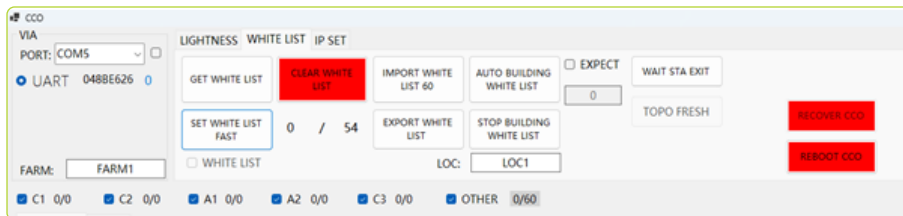

20.

Commissioning

1. Plug the serial cable in the RS-232 port (G) on the transmitter.
2. Connect the cable to your PC.
3. Switch on the transmitter.
4. Start the software.
5. Select the serial port to use in the dropdown menu.

The system will now connect to the selected port, if the connection is successfully made, the serial number is displayed behind UART and the log on the right side shows some messages.

6. Go to the "WHITE LIST" tab.
7. Click on "AUTO BUILDING WHITELIST".

A list of all luminaires that are powered on will be generated. The transmitter establishes a network with all luminaires from this list. As luminaires are found, the count at the top of the screen will increase until it matches the number of luminaires to be commissioned.

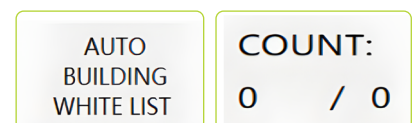

8. Click on "STOP BUILDING WHITELIST" to complete the whitelist. The luminaires are now commissioned and can be grouped.

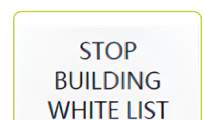

Note: The grouping process is applicable for 2023 and later luminaires

9. Click on “GET WHITE LIST FAST(BETA)”, this process may take a few seconds.
 - If the list does not appear immediately, click a few times until it does.
 - Wait until the list appears, the list loads in increments of 10 luminaires.

GET WHITE LIST FAST(BETA)

10. Once the whitelist is visible, it must be saved.
 - Click “EXPORT WHITE LIST”. A pop-up will appear.
 - Click “Yes” and then “OK” on the next pop-up to confirm. The whitelist will be saved as a .txt file in the “publish” folder. It will be named “WHITELIST_XXXXXXXX_YYYYMMDD”, with therelevant ID, date, and time.
 - Copy, rename, and store this file as a backup.

EXPORT WHITE LIST

9.5. Information handling

Proper and careful handling of all information is essential, for example, to facilitate any future adjustments, such as changing luminaires.

- All .txt files with serial numbers should be stored appropriately with their corresponding group number.
- They should have a standard name and be meticulously kept in folders, including numbering the name of the associated cabinet.
- If the number of luminaires per compartment varies, this figure should be included after the group in the name.

To be saved as follows:

Customer name	SampleGrower B.V.
Switch cabinet	BP01.123
Whitelist .txt files	“Group2 25.txt” “Group3 35.txt” “Group4 25.txt” “Group5 54.txt”

9.6. Transmitter control

9.6.1. Modbus RTU

Each transmitter must have its own unique MODBUS address.

1. Go to the “ADDR SETTING” tab.
2. Click on “MODBUS ADDR”.
3. Enter the number assigned to that transmitter and click “SET”.

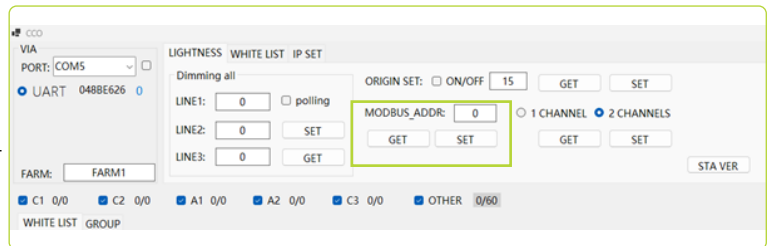

21.

Check on the right side of the message screen if it worked and verify the address with GET.

9.6.2. Modbus TCP

Each transmitter must have its own unique IP-address.

1. Go to the “ADDR SETTING” tab.
2. Click on “MODBUS ADDR”.
3. Enter the IP, GW, MASK and click “SET”.

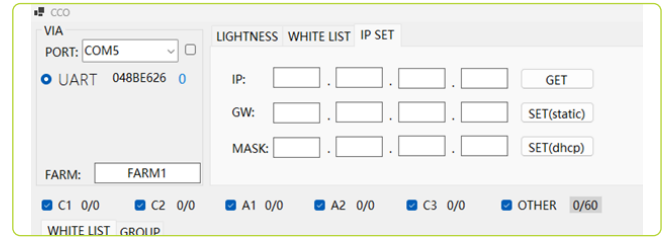

22.

Check on the right side of the message screen if it worked and verify the IP-address with GET.

9.6.3. 0 - 10V

For 0 - 10V control:

1. Go to the “LIGHTNESS” tab.
2. Select 1 or 2 channels, depending on your luminaires.
3. Press SET.

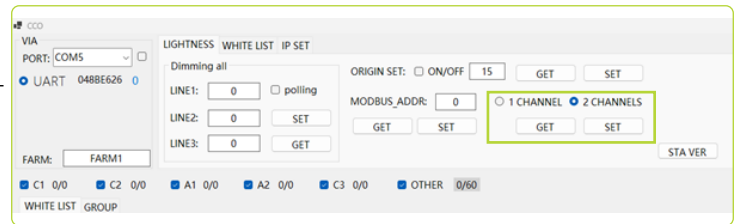

23.

9.6.4. START-UP CONTROL

To reduce startup level:

1. Go to the “LIGHTNESS” tab.
2. Check the box for “ORIGIN SET” to turn it ON.
3. Fill in the field VALUE (%). Valid values are 0% or 15 - 100%

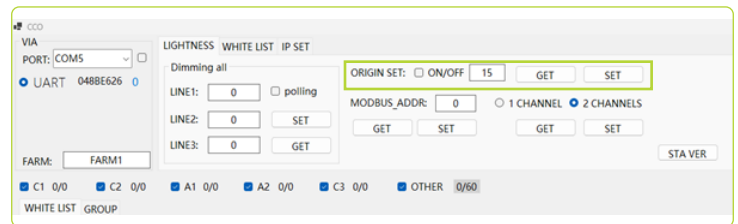

24.

- ! **Note:** This procedure only configures the currently connected luminaires. When additional luminaires are added to the transmitter, this behavior must be programmed again.

9.7. Temporary manual dimming set-up

This is the period during which you want to provide illumination once the transmitters are installed and commissioned, but before the Modus system is fully operational.

1. Switch on the transmitters.
2. Select the “LIGHTNESS” tab in the Agrolux Transmitter Software program.
3. In the “Dimming all” field, enter the desired percentage. LINE 1 is PAR and LINE 2 is Far Red. For example: LINE 1 800 (80%) LINE 2 1000 (100%).

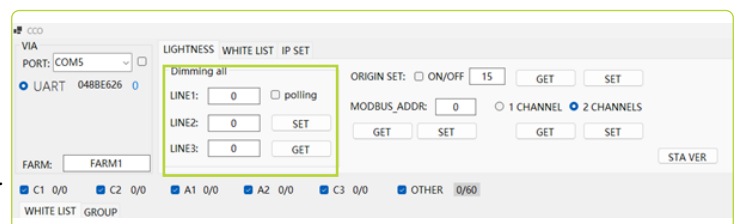

25.

9.8. Commissioning with groups

When commissioning groups, do commissioning in a phased approach.
General way of working is the following:

1. Switch on only the luminaires that you want in a single group.
2. Commission the luminaires normally, see the previous paragraphs.
3. Move the luminaires from Group 1 to another Group, see instructions below.
4. Switch off the luminaires.
5. Repeat steps 1 – 4 for the next group(s).

Note: It is important to note that Group 1 should only be used as a placeholder for new luminaires. Commissioned luminaires are automatically placed in Group 1. By keeping Group 1 free of commissioned luminaires, users can easily distinguish between luminaires that have been commissioned and those that have not.

9.8.1. Assigning luminaires to groups

1. Go to the WHILELIST tab.
2. Click the GET whitelist button to ensure you have an actual list.
3. Go to the GROUP tab in the bottom view of the application.
4. Click Refresh Groups to get up-to-date group information.
5. Select the luminaires you want to move to a new group.
6. Click on the >> TO# button, where # is the number of the designated group.

This process may take up to 4 seconds per luminaire.

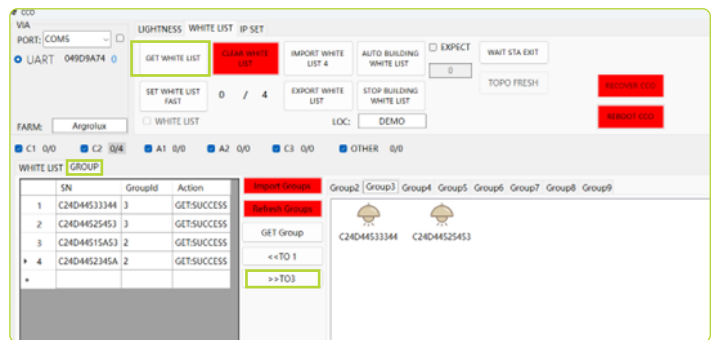

26.

7. Navigate to the "GroupId" tab to verify that all luminaires have been assigned to the correct group.

1. Cleaning

1.1. Before cleaning

Before cleaning the luminaires, keep the following into account to not void your warranty and avoid dangerous situations:

- Disconnect the product from mains before handling.
- Do not connect or disconnect the Wieland RST20i3 plug under load.
- Do not open or disassemble the luminaire, it contains no serviceable parts inside.
- Use a cool down period of at least 30 minutes before touching the lamp or luminaire.

1.2. Regular inspection

To fully enjoy the benefits of the products we advise to regularly inspect the luminaires. Check whether the wiring of the lightning is in good condition and check the luminaires for dust or dirt buildup. Clean, if necessary, to avoid contamination and guarantee the best performance.

When maintenance is necessary, contact our warranty and maintenance department (service@gavitainternational.com) to perform the maintenance for you.

1.3. Cleaning

For properly cleaning your Luminaires we advise you to take the following into account:

- Dry or a damp cloth are best suitable for cleaning the outside of the luminaire;
- Do not use a high pressure water gun;
- Do not touch the optics with your hands and use the right cleaning products;
- Detergents, abrasives or other aggressive substances can damage the insides of the luminaire.
We advise to use LightShine cleaning wipes available at www.lightshine.nl

Or use the table below to check which substances are suitable.

Use	Do not use
✓ Isopropyl alcohol	✗ Acetone
✓ Hydrogen Peroxide 10 – 50 %	✗ Ethyl alcohol
✓ Ozone	✗ Methyl alcohol
✓ Soap Solutions	✗ Ammonia, liquid
✓ Water, distilled	✗ Clorox (Bleach)
✓ Water, fresh	✗ Any other agent that can affect the optics
✓ Water, salt	

2. Warranty

For warranty terms, visit our website agrolux.com.

3. Storage and disposal

- Store the luminaire in a dry and clean environment, with an environmental temperature of 0 - 65 °C (32 - 149 F).
-  The product must not be discarded as unsorted municipal waste, but must be collected separately for the purpose of treatment, recovery and environmentally sound disposal.

